

D22 PIN DETAIL
SCALE: 3/4" = 1'-0"

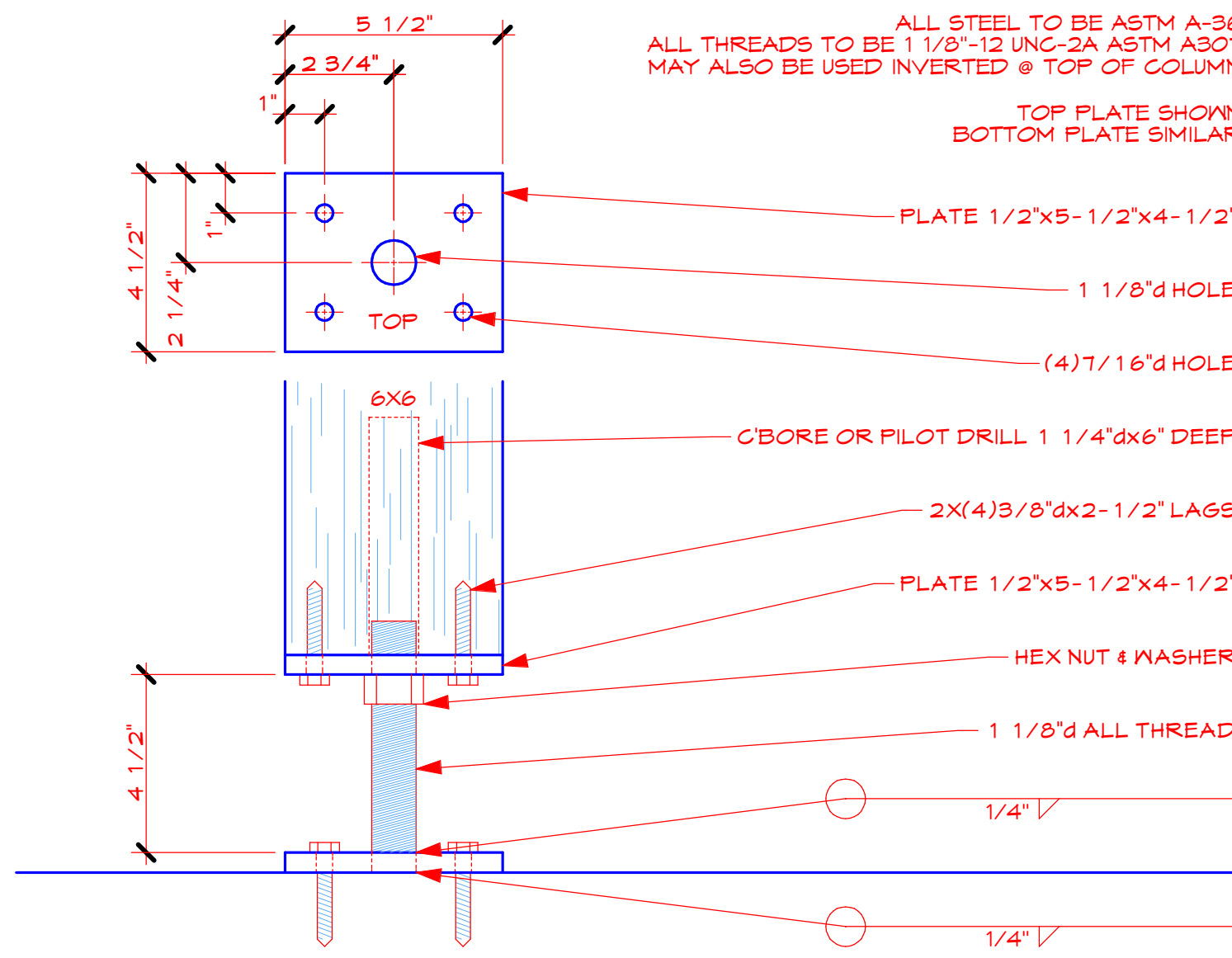

D23 TYPE 2 ADJUSTER DETAIL
SCALE: 3/4" = 1'-0"

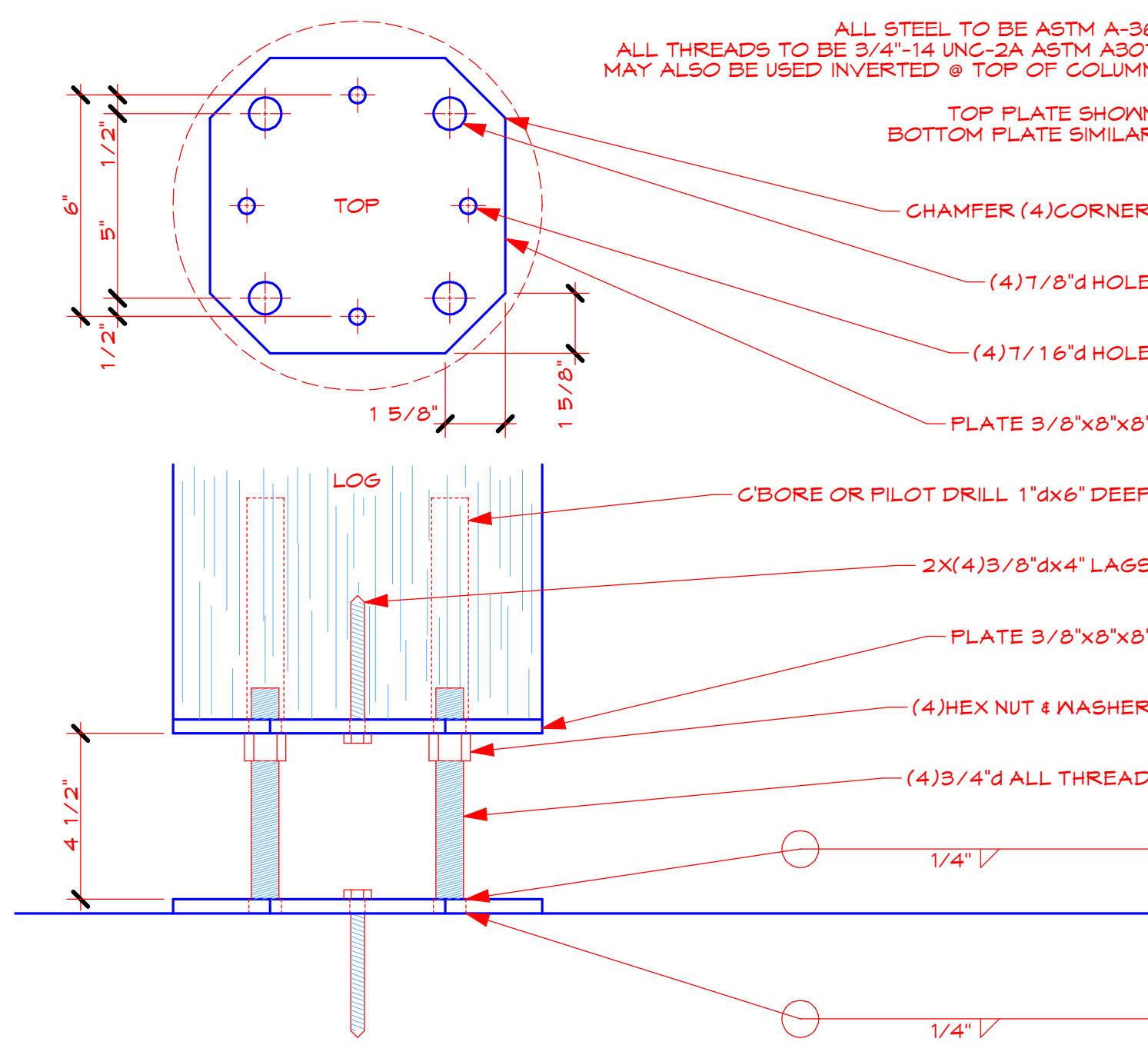

D24 TYPE 3 ADJUSTER DETAIL
SCALE: 3/4" = 1'-0"

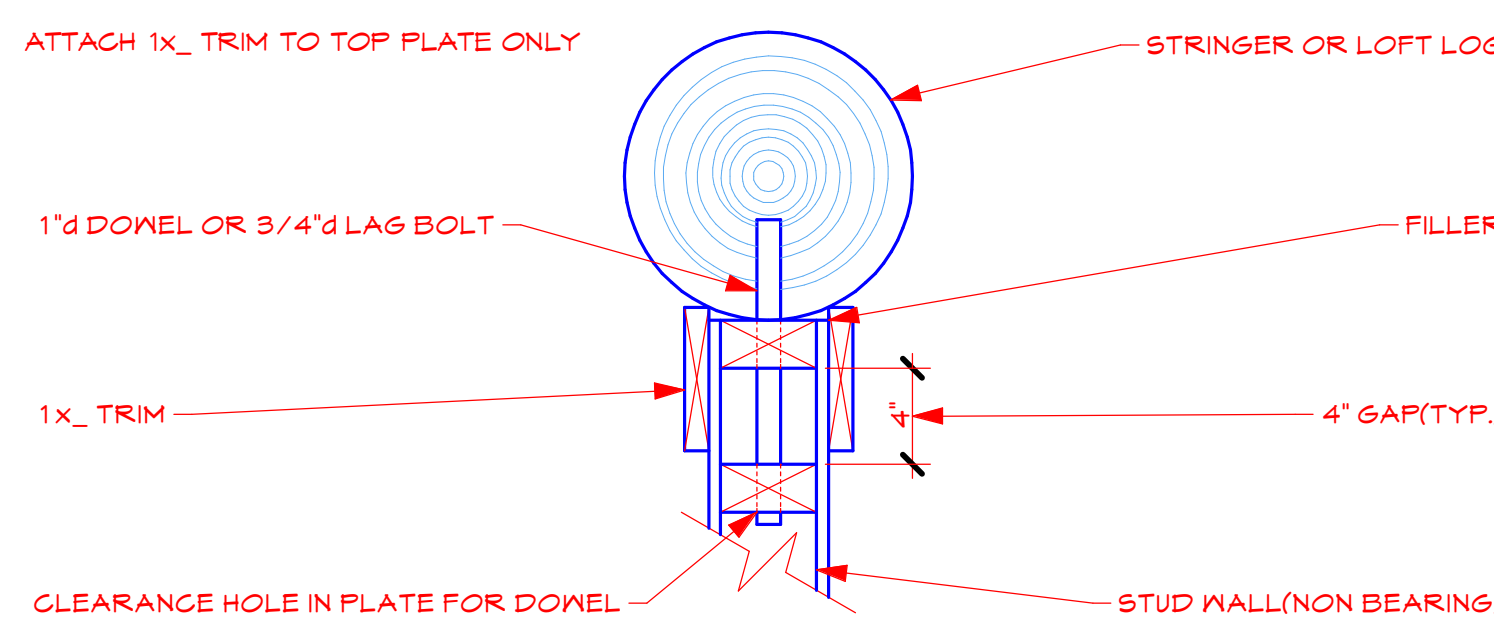

D25 SLIP JOINT DETAIL
SCALE: 1 1/2" = 1'-0"

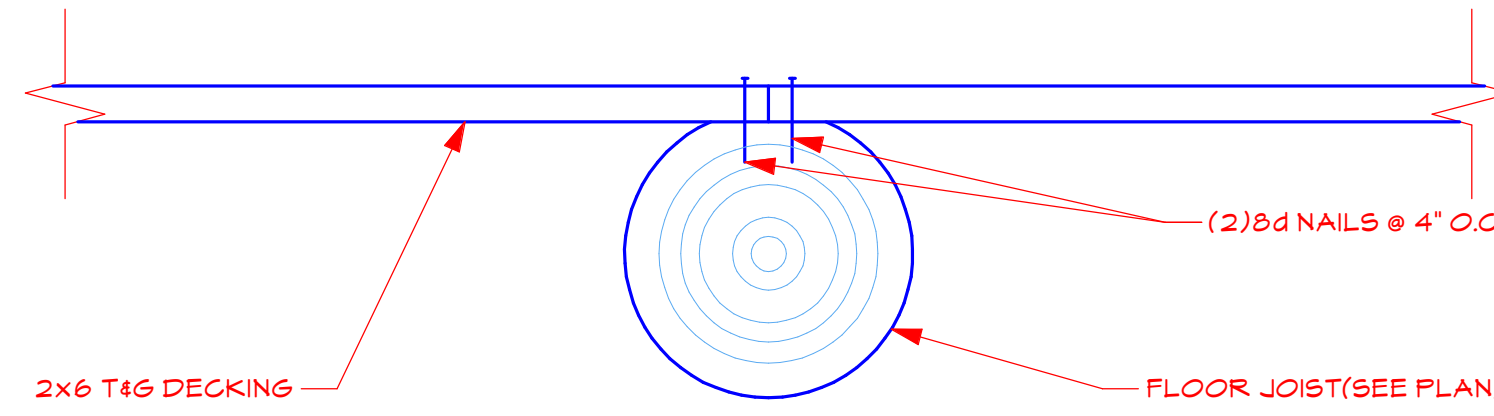

D26 LOFT LOG TO DECKING
SCALE: 1 1/2" = 1'-0"

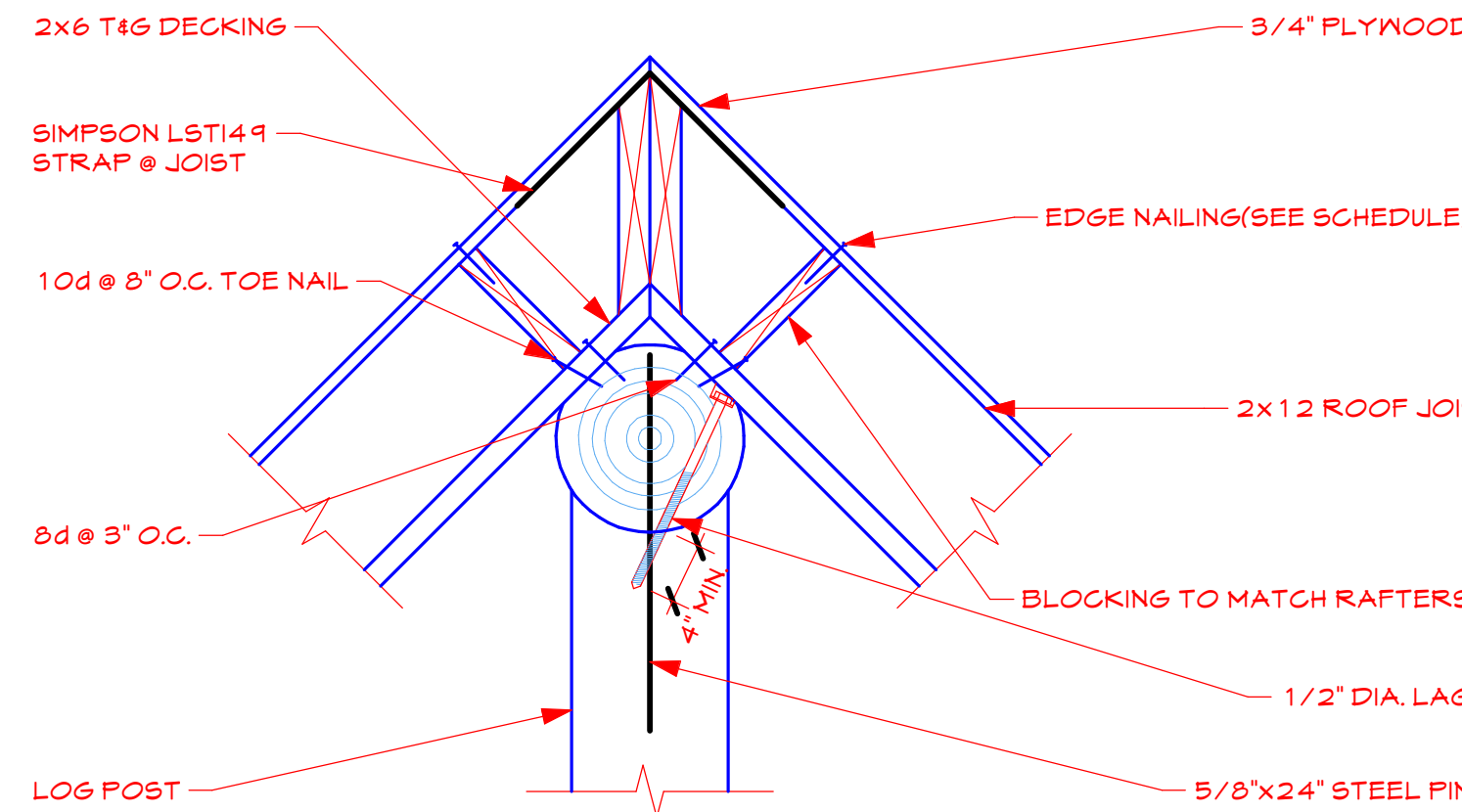

D27 ROOF TO RIDGE CONNECTION
SCALE: 1" = 1'-0"

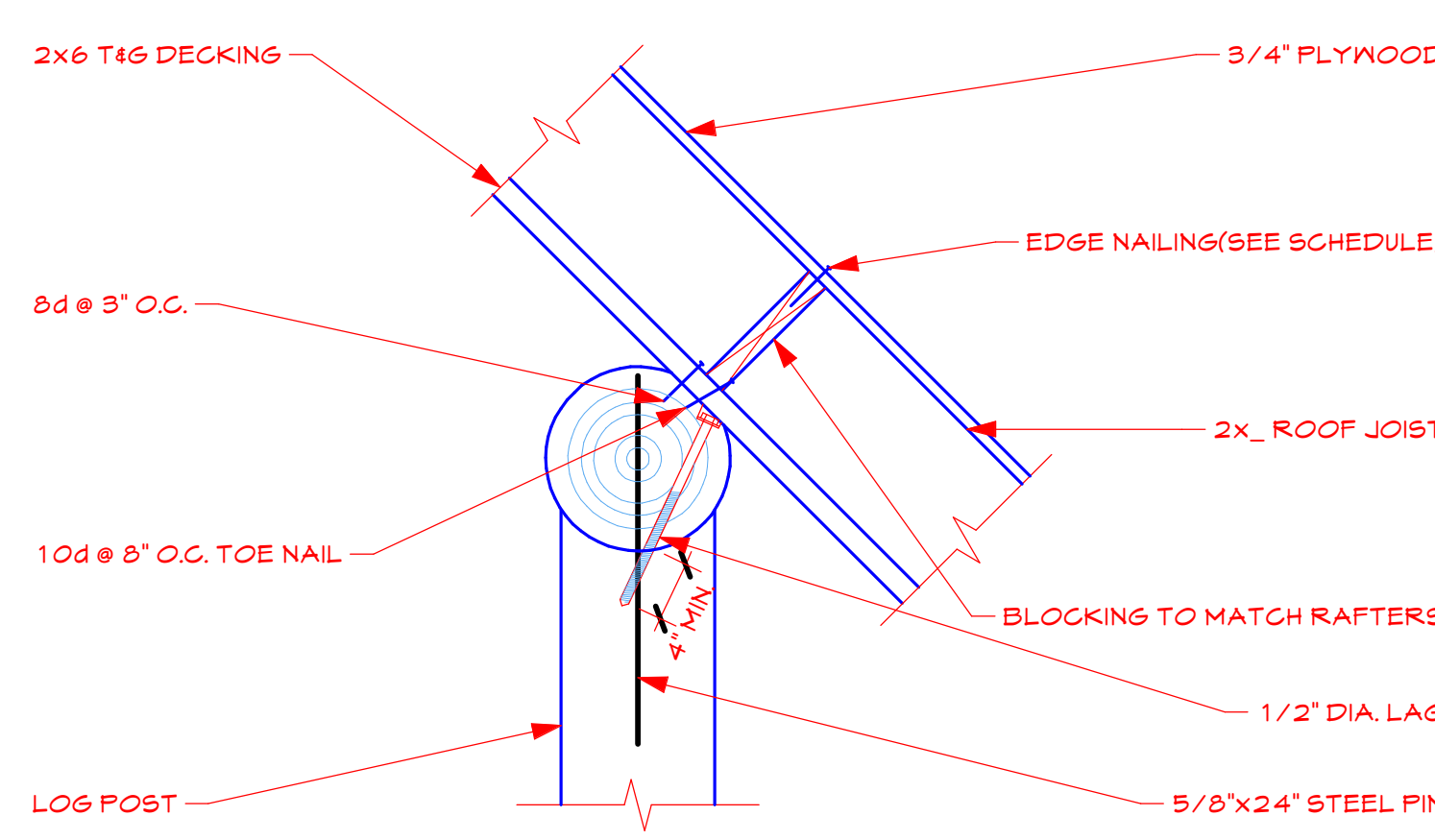

D28 ROOF TO PURLIN CONNECTION
SCALE: 1" = 1'-0"

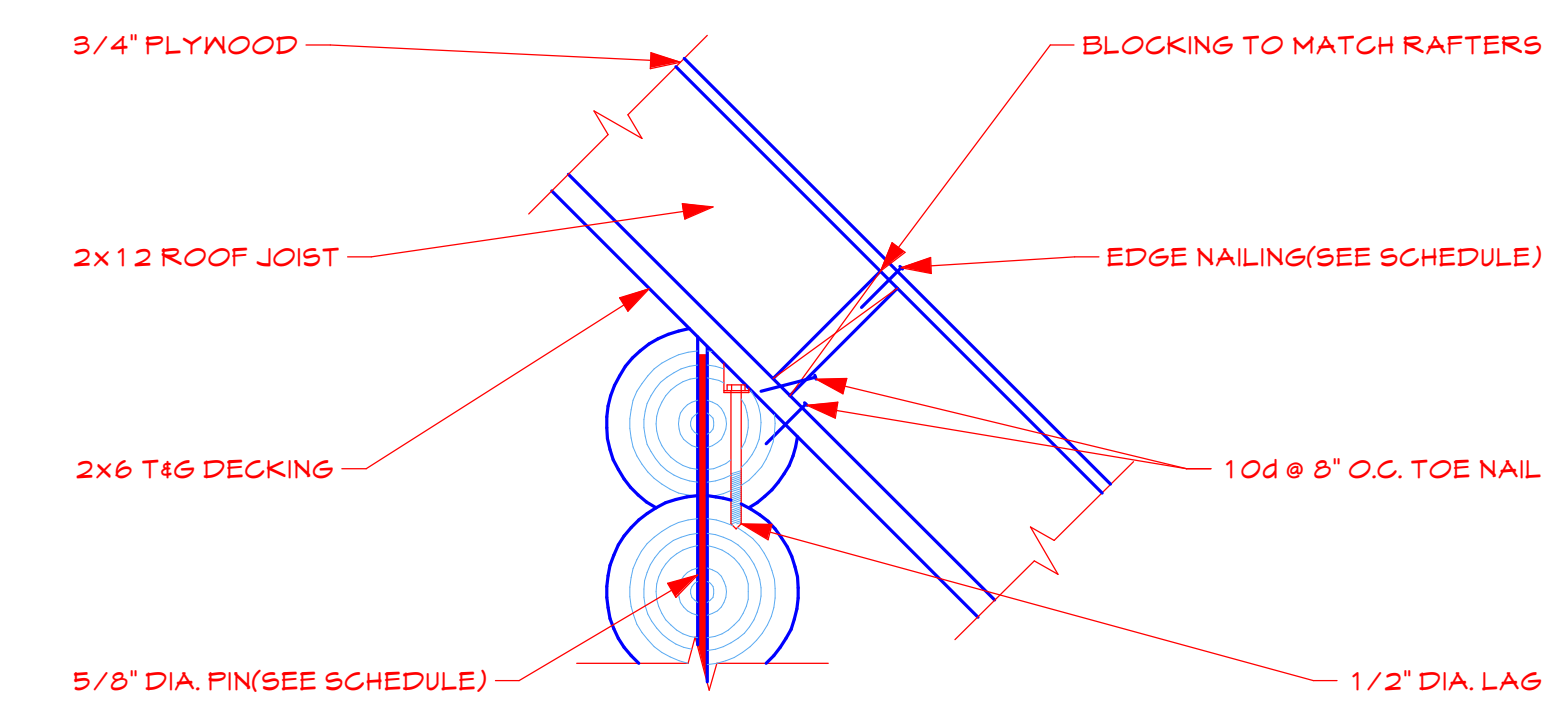

D29 ROOF TO PLATE CONNECTION
SCALE: 1" = 1'-0"

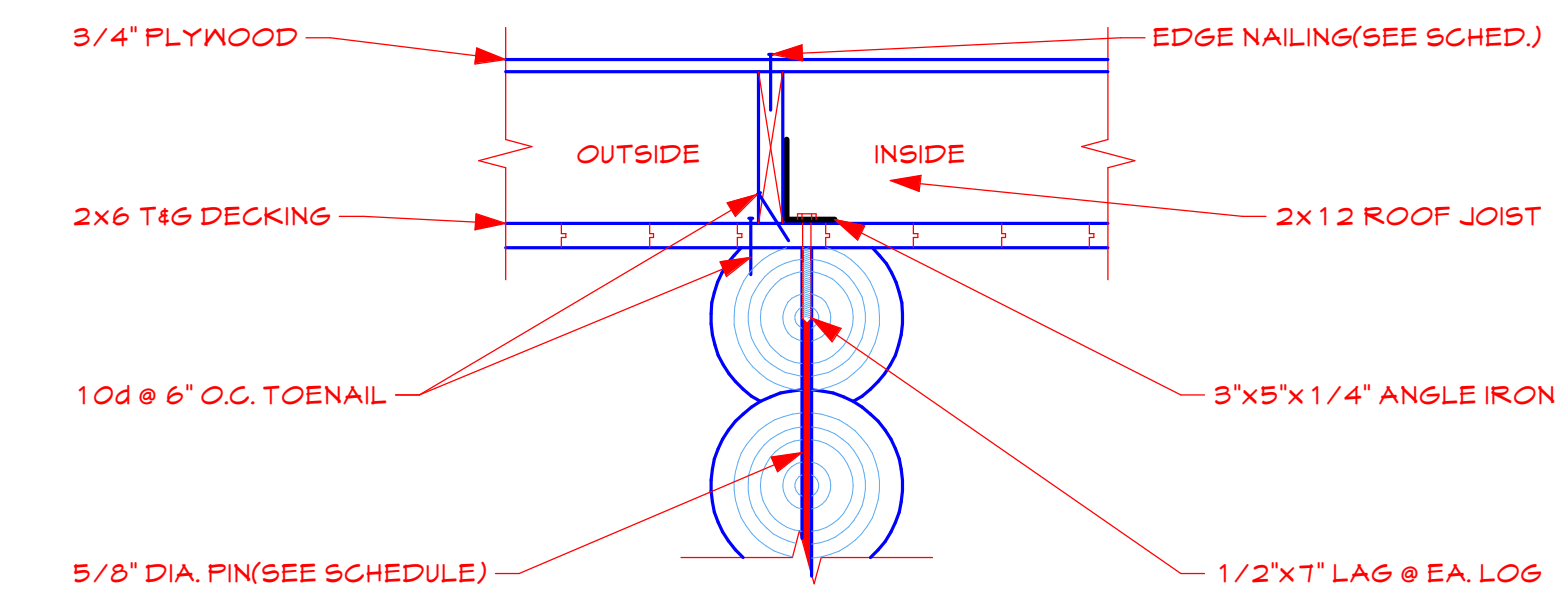

D30 ROOF TO GABLE CONNECTION
SCALE: 1" = 1'-0"

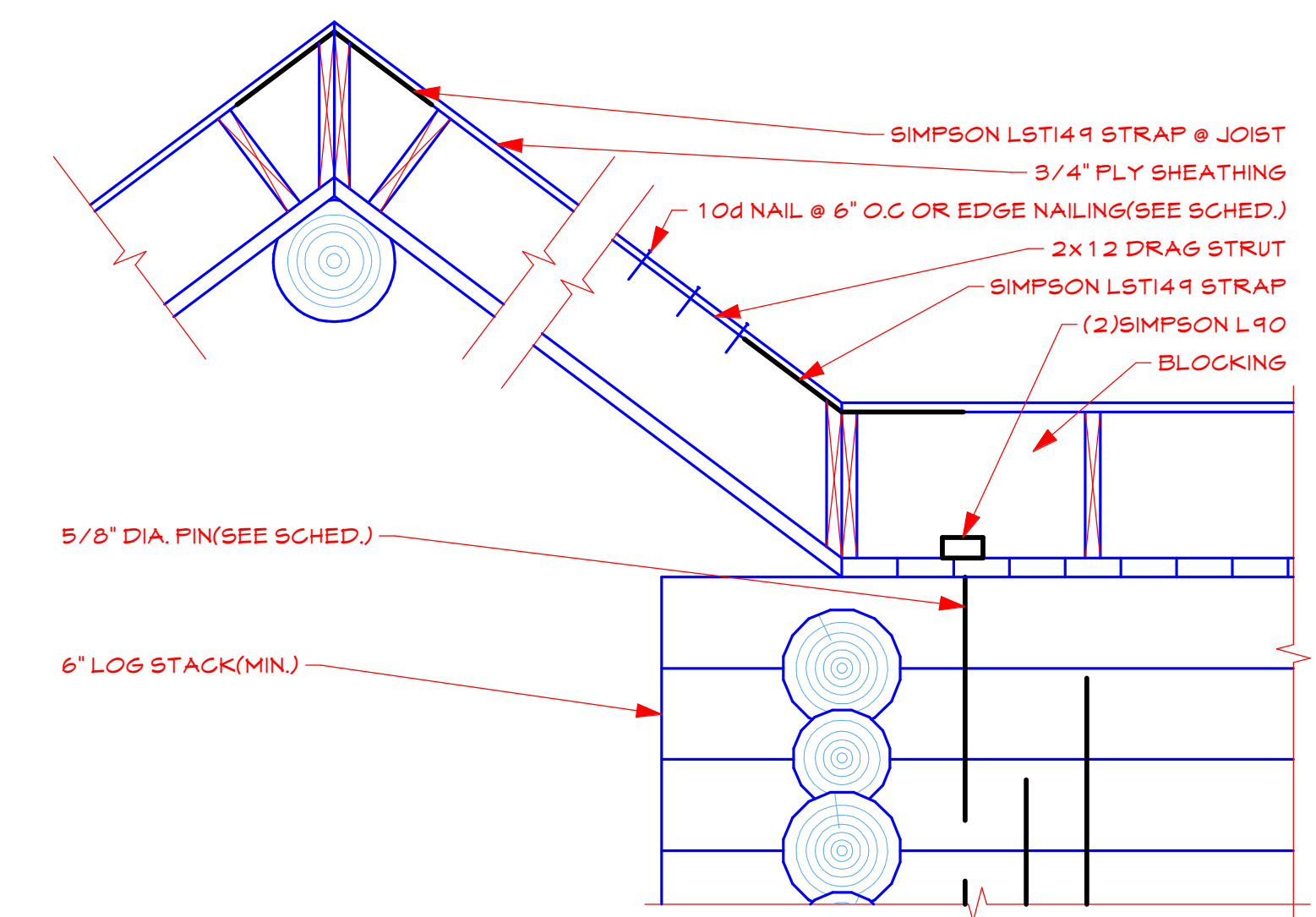

D31 ROOF TO WALL CONNECTION
SCALE: 3/4" = 1'-0"

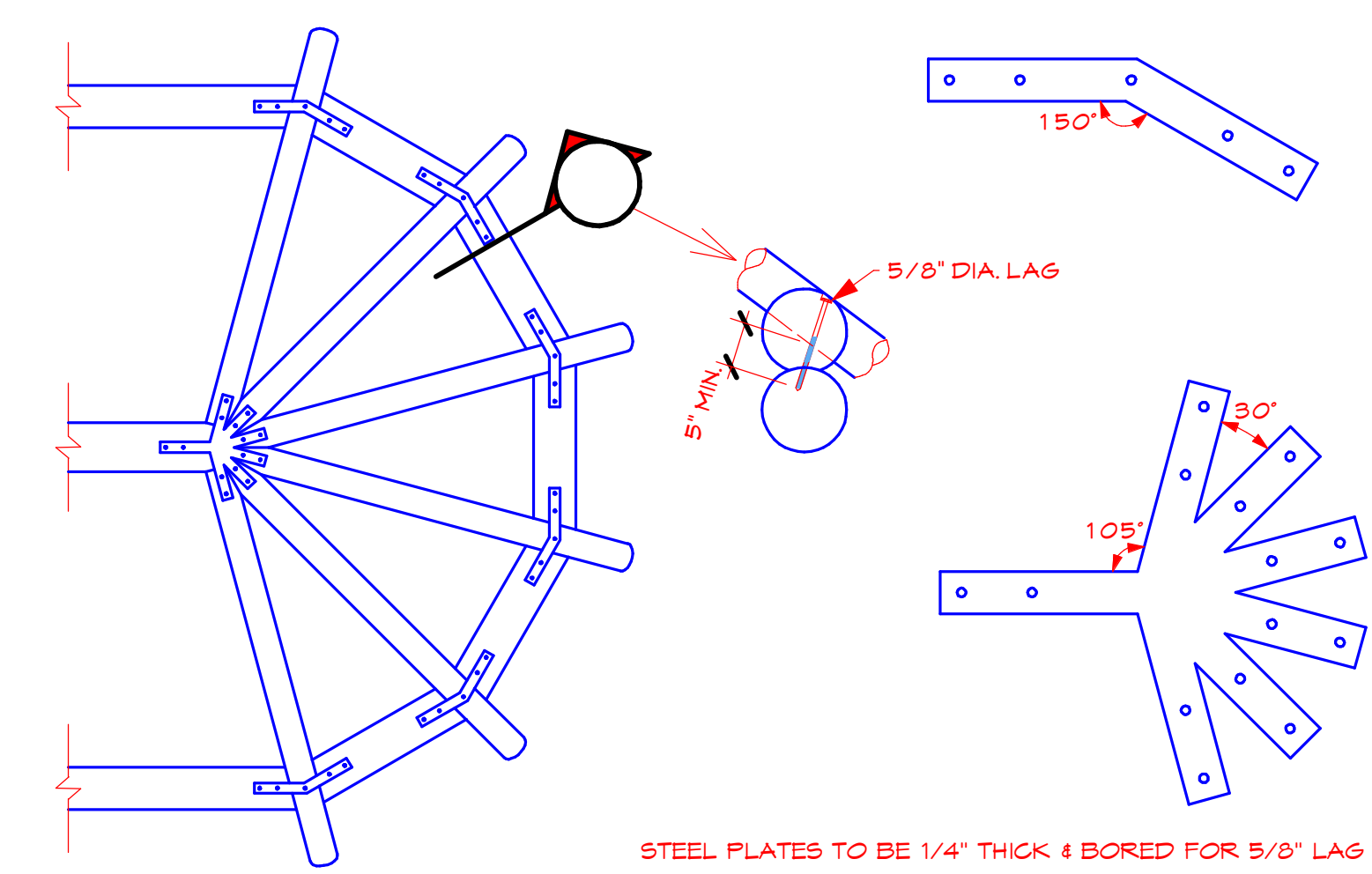

D32 LOG RAFTER CONNECTIONS
N.T.S.